

90-1 Turn/Stop/Hazard Lamps

➤ Component ➤ Connector ➤ Ground ➤ Splice ➤ Page ➤ Harness

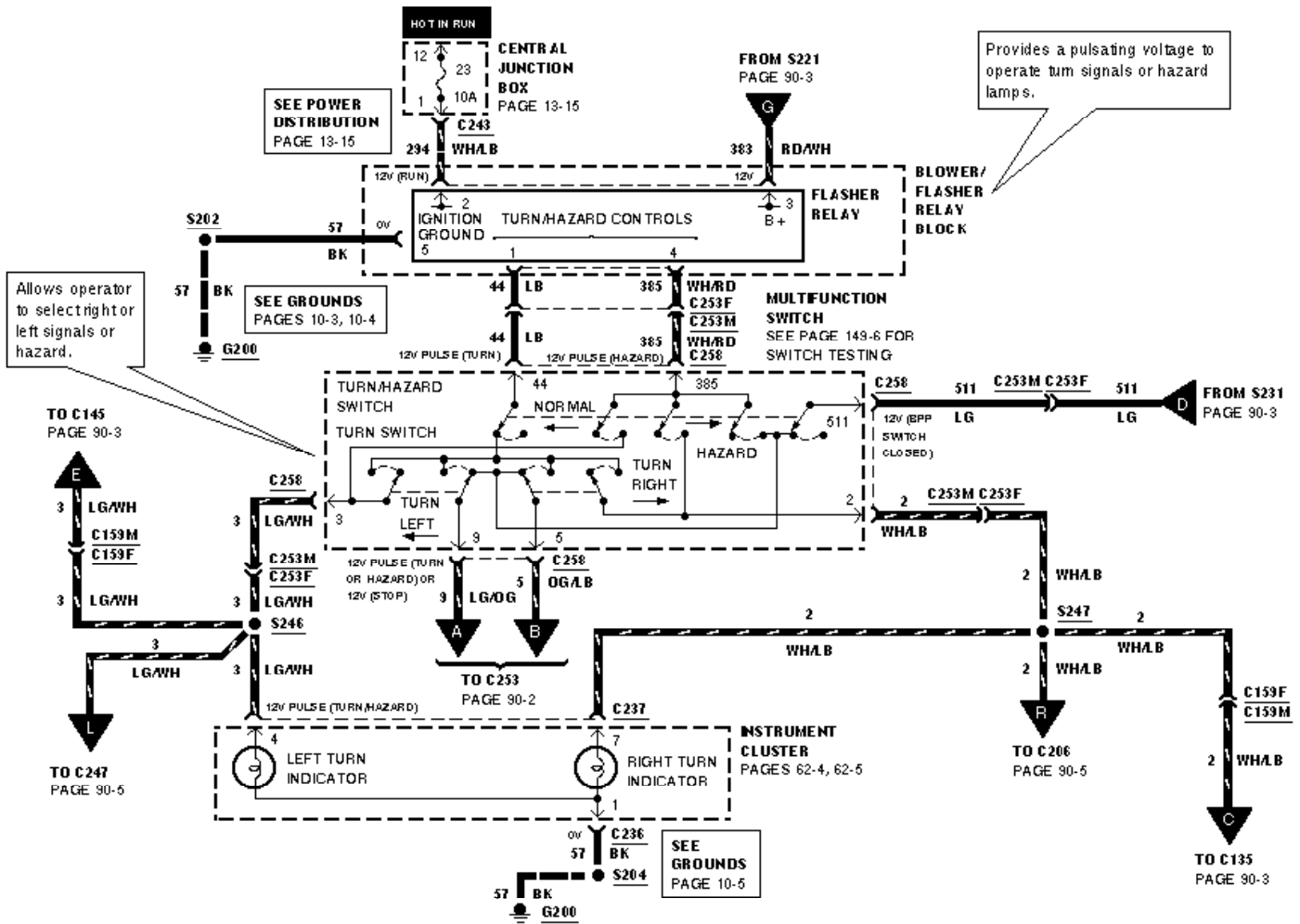

90-2 Turn/Stop/Hazard Lamps

➤ Component ➤ Connector ➤ Ground ➤ Splice ➤ Page ➤ Harness

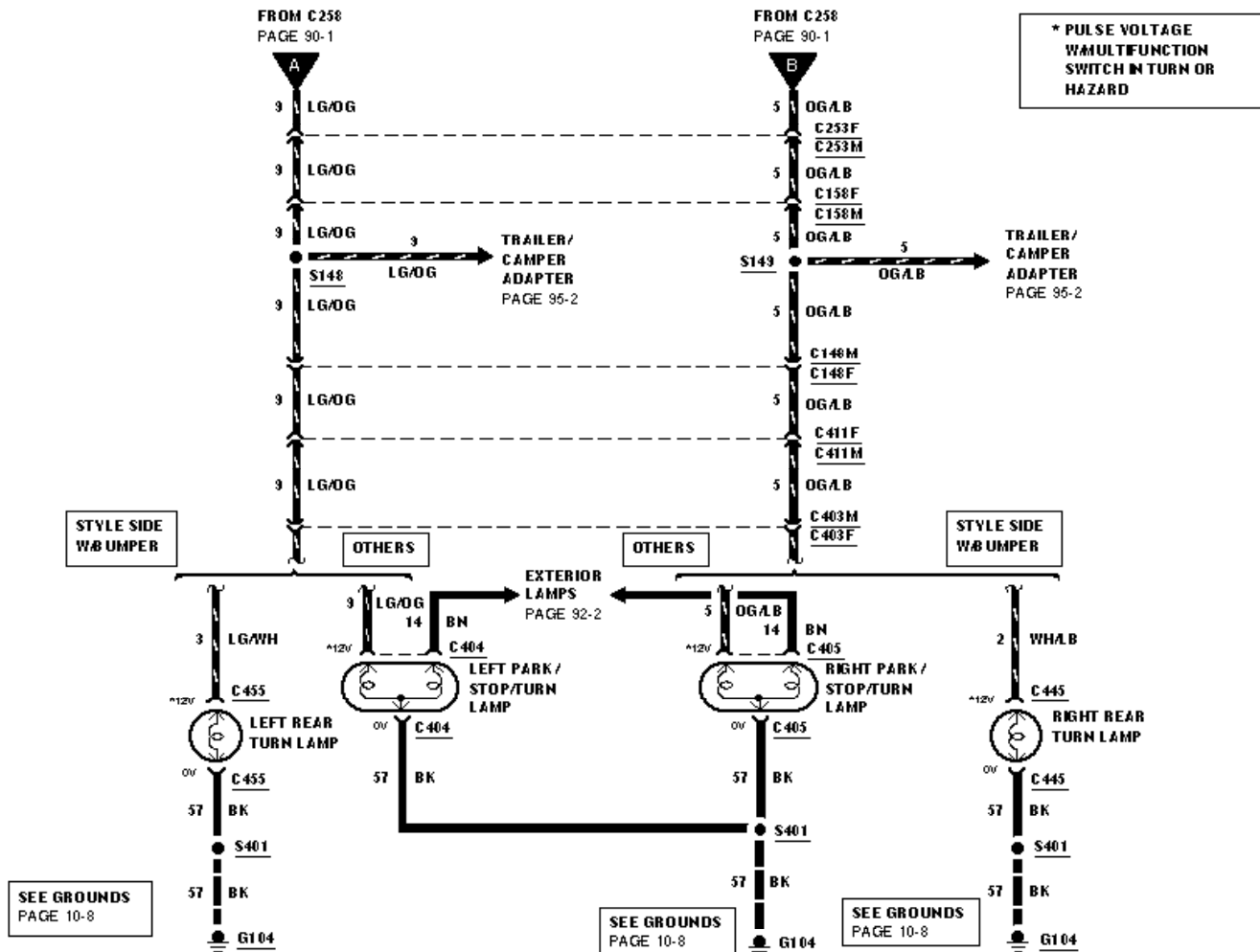

90-3 Turn/Stop/Hazard Lamps

- Component
- Connector
- Ground
- Splice
- Page
- Harness

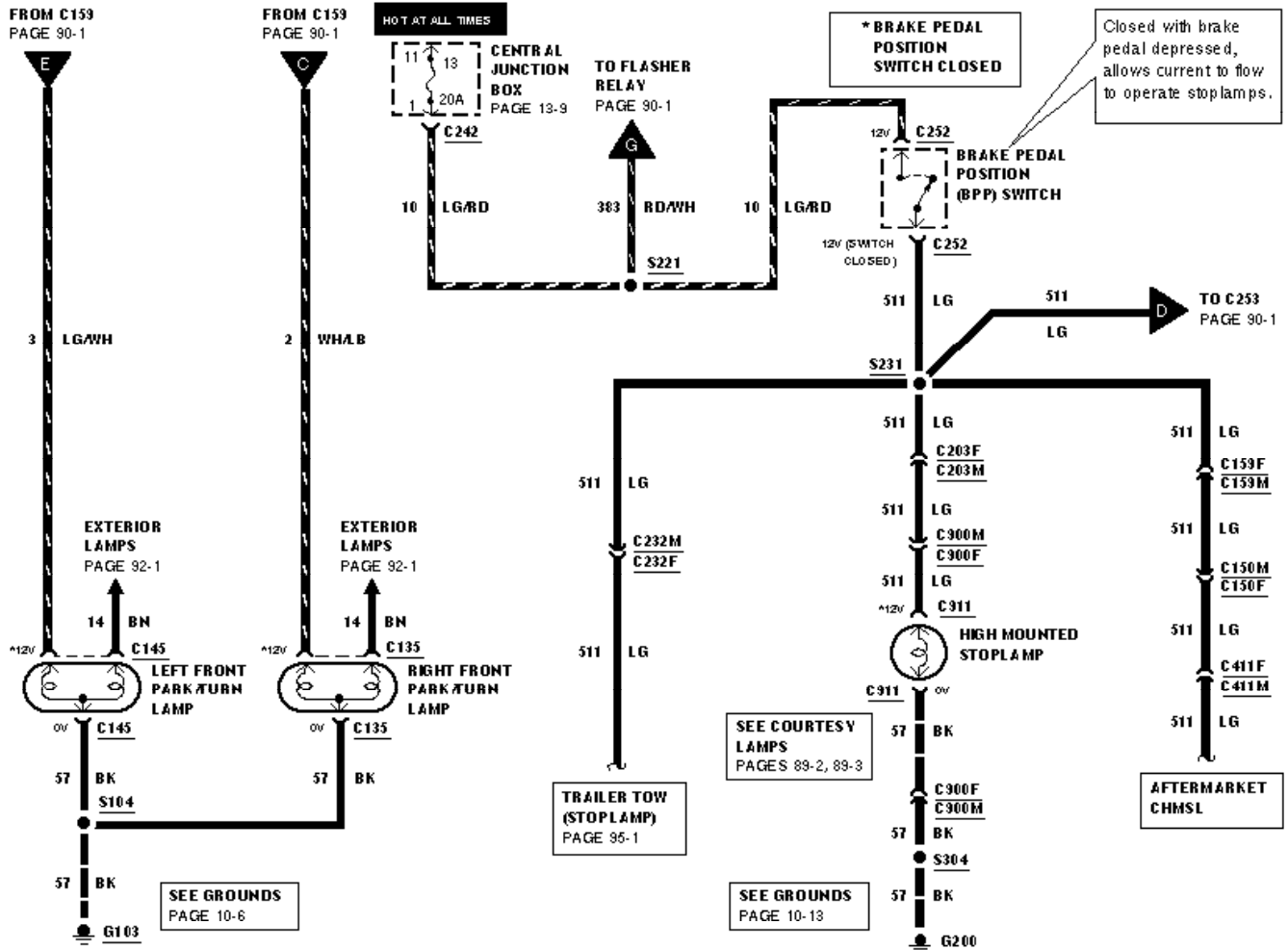

90-4 Turn/Stop/Hazard Lamps

- Component
- Connector
- Ground
- Splice
- Page
- Harness

HOT AT ALL TIMES

* BRAKE PEDAL POSITION SWITCH CLOSED

SEE POWER DISTRIBUTION PAGE 13-16

CENTRAL JUNCTION BOX PAGE 13-9

Closed with brake pedal depressed, allows current to flow to operate stoplamps.

SEE GROUNDS PAGE 10-11

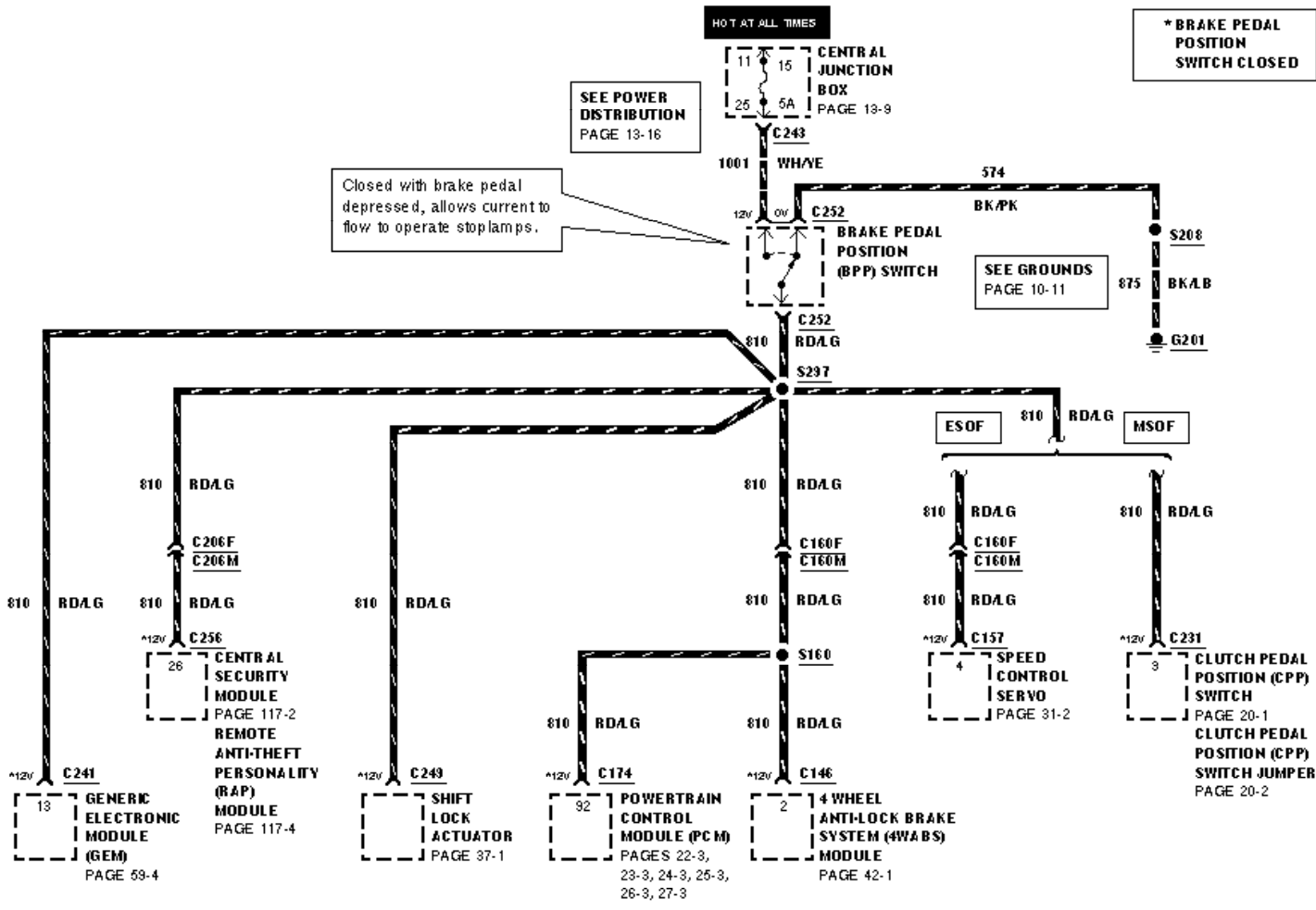

90-5 Turn/Stop/Hazard Lamps

- Component
- Connector
- Ground
- Splice
- Page
- Harness

HOT AT ALL TIMES

FROM S246
PAGE 90-1

* SUPER CREW

FROM S247
PAGE 90-1

HOT AT ALL TIMES

